

NL7WB66

Ultra-Small SPST Analog Switch

The NL7WB66 is a very low R_{ON} dual SPST analog switch. R_{ON} is 5.0 Ω (Typ) at 5.0 V. The device is offered in the very popular low cost US8 package. It is designed as a general purpose dual switch and can be used to switch either analog signals such as audio and video or digital signal such as TTL, CMOS, LVDS, ECL, or complex digital signals such as QPSK.

Features

- Excellent Performance $RDS_{ON} = 5.0 \Omega$ at 5.0 V
- High Speed Operation: $t_{PD} = 0.25$ ns (Max) at 5.0 V
- 1.65 to 5.5 V Operating Range
- Reduced Threshold Voltages for LVTTTL on Control Pin
 - ◆ Eliminates the Need for Translators for Many Applications
 - ◆ TTL Compatibility when V_{CC} is 5.0 V
 - ◆ Can Operate with 1.8 V Inputs, if V_{CC} is 3.0
 - ◆ Also Meets Full CMOS Specifications
- Ultra-Low Charge Injection = 7.5 pC at 5.0 V
- Low Stand-by Power $I_{CC} = 1.0$ nA (Max) at $T_A = 25^\circ\text{C}$
- Control Pins IN1, IN2, are Overvoltage Tolerant
- Pin for Pin Replacement TC7WB66, NC7WB66, 74LVC2G66
- ESD Protection:
 - Machine Model >200 V,
 - Human Body Model >2000 V
- Latchup Max Rating: 200 mA
- These Devices are Pb-Free, Halogen Free/BFR Free and are RoHS Compliant

Typical Applications

- Cell Phones
- PDAs
- Digital Still Cameras
- Video
- Digital Video

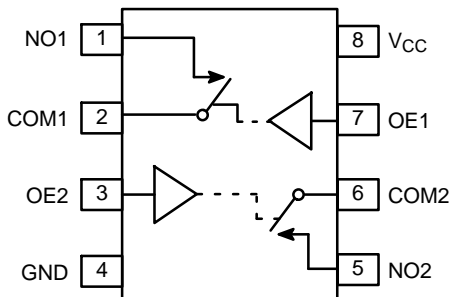
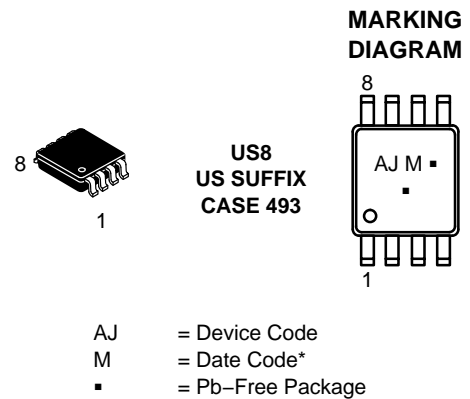

Figure 1. Pin Assignment Diagram



ON Semiconductor®

www.onsemi.com



(Note: Microdot may be in either location)

*Date Code orientation may vary depending upon manufacturing location.

PIN ASSIGNMENT

Pin	Function	OVT
1	NO1	–
2	COM1	–
3	OE2	Yes
4	GND	–
5	NO2	–
6	COM2	–
7	OE1	Yes
8	V_{CC}	–

FUNCTION TABLE

On/Off Enable Input	State of Analog Switch
L	Off
H	On

ORDERING INFORMATION

See detailed ordering and shipping information in the package dimensions section on page 5 of this data sheet.

NL7WB66

MAXIMUM RATINGS

Symbol	Rating	Value	Unit
V _{CC}	DC Supply Voltage	-0.5 to +7.0	V
V _I	DC Input Voltage	-0.5 to +7.0	V
V _O	DC Output Voltage	-0.5 to +7.0	V
I _{IK}	DC Input Diode Current V _I < GND	-50	mA
I _{OK}	DC Output Diode Current V _O < GND	-50	mA
I _O	DC Output Sink Current	±50	mA
I _{CC}	DC Supply Current per Supply Pin	±100	mA
I _{GND}	DC Ground Current per Ground Pin	±100	mA
T _{STG}	Storage Temperature Range	-65 to +150	°C
T _L	Lead Temperature, 1 mm from Case for 10 Seconds	260	°C
T _J	Junction Temperature under Bias	+150	°C
θ _{JA}	Thermal Resistance	250	°C/W
P _D	Power Dissipation in Still Air at 85°C	250	mW
MSL	Moisture Sensitivity	Level 1	-
F _R	Flammability Rating Oxygen Index: 28 to 34	UL 94 V-0 @ 0.125 in	-
V _{ESD}	ESD Withstand Voltage Human Body Model (Note 2) Machine Model (Note 3) Charged Device Model (Note 4)	> 2000 > 200 N/A	V

Stresses exceeding those listed in the Maximum Ratings table may damage the device. If any of these limits are exceeded, device functionality should not be assumed, damage may occur and reliability may be affected.

1. Measured with minimum pad spacing on an FR4 board, using 10 mm-by-1 inch, 2-ounce copper trace with no air flow.
2. Tested to EIA/JESD22-A114-A.
3. Tested to EIA/JESD22-A115-A.
4. Tested to JESD22-C101-A.

RECOMMENDED OPERATING CONDITIONS

Symbol	Characteristics	Min	Max	Unit
V _{CC}	Positive DC Supply Voltage	1.65	5.5	V
V _{IN}	Digital Input Voltage (Enable)	GND	5.5	V
V _{IO}	Static or Dynamic Voltage Across an Off Switch	GND	V _{CC}	V
V _{IS}	Analog Input Voltage NO COM	GND	V _{CC}	V
T _A	Operating Temperature Range, All Package Types	-55	+125	°C
t _r , t _f	Input Rise or Fall Time (Enable Input) V _{CC} = 3.3 V ± 0.3 V V _{CC} = 5.0 V ± 0.5 V	0 0	100 20	ns/V

Functional operation above the stresses listed in the Recommended Operating Ranges is not implied. Extended exposure to stresses beyond the Recommended Operating Ranges limits may affect device reliability.

DEVICE JUNCTION TEMPERATURE VS. TIME TO 0.1% BOND FAILURES

Junction Temperature °C	Time, Hours	Time, Years
80	1,032,200	117.8
90	419,300	47.9
100	178,700	20.4
110	79,600	9.4
120	37,000	4.2
130	17,800	2.0
140	8,900	1.0

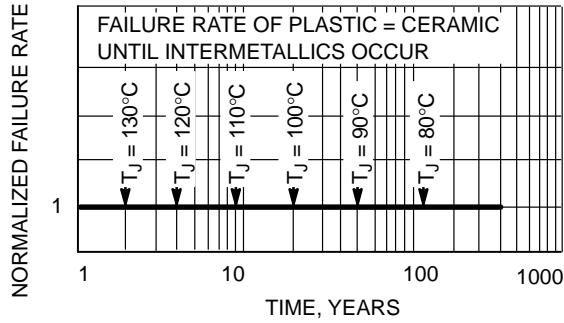

Figure 2. Failure Rate vs. Time Junction Temperature

DC CHARACTERISTICS – Digital Section (Voltages Referenced to GND)

Symbol	Parameter	Condition	V _{CC}	Guaranteed Max Limit			Unit
				25°C	-40 to 85°C	-55 to <125°C	
V _{IH}	High-level Input Voltage, Control Input		1.65 to 1.95 2.3 to 2.7 3.0 to 3.6 4.5 to 5.5	V _{CC} x 0.65 V _{CC} x 0.7 V _{CC} x 0.7 V _{CC} x 0.7	V _{CC} x 0.65 V _{CC} x 0.7 V _{CC} x 0.7 V _{CC} x 0.7	V _{CC} x 0.65 V _{CC} x 0.7 V _{CC} x 0.7 V _{CC} x 0.7	V
V _{IL}	Low-level Input Voltage, Control Input		1.65 to 1.95 2.3 to 2.7 3.0 to 3.6 4.5 to 5.5	V _{CC} x 0.35 V _{CC} x 0.3 V _{CC} x 0.3 V _{CC} x 0.3	V _{CC} x 0.35 V _{CC} x 0.3 V _{CC} x 0.3 V _{CC} x 0.3	V _{CC} x 0.35 V _{CC} x 0.3 V _{CC} x 0.3 V _{CC} x 0.3	V
I _{IN}	Maximum Input Leakage Current, Enable Inputs	V _{IN} = 5.5 V or GND	0 V to 5.5 V	±0.1	±1.0	±1.0	µA
I _{CC}	Maximum Quiescent Supply Current (per package)	Enable and VIS = V _{CC} or GND	5.5	1.0	1.0	2.0	µA

Product parametric performance is indicated in the Electrical Characteristics for the listed test conditions, unless otherwise noted. Product performance may not be indicated by the Electrical Characteristics if operated under different conditions.

NL7WB66

DC ELECTRICAL CHARACTERISTICS – Analog Section

Symbol	Parameter	Condition	V _{CC}	Guaranteed Max Limit			Unit
				25°C	-40 to 85°C	-55 to <125°C	
R _{ON}	On-State Switch Resistance	V _{IS} = V _{CC} I _S = 4 mA	1.65	30	30	30	Ω
		V _{IS} = GND I _S = 4 mA	1.65	15	15		
		V _{IS} = V _{CC} I _S = 8 mA	2.3	20	20		
		V _{IS} = GND I _S = 8 mA	2.3	10	10		
		V _{IS} = V _{CC} I _S = 24 mA	3.0	15	15		
		V _{IS} = GND I _S = 24 mA	3.0	7.0	7.0		
		V _{IS} = V _{CC} I _S = 32 mA	4.5	10	10		
		V _{IS} = 2.4 I _S = 15 mA	4.5	8.0	8.0		
		V _{IS} = GND I _S = 32 mA	4.5	5.0	5.0		
R _{ON(p)}	Peak On-State Resistance	V _{IS} = V _{CC} to GND, I _S = 4 mA V _{IN} = V _{IH} I _S = 8 mA I _S = 24 mA I _S = 32 mA	1.65 2.3 3.0 4.5	120 30 20 15	120 30 20 15	120 30 20 15	Ω
Δ R _{ON}	Difference of On-State Resistance between Switches	V _{IS} = V _{CC} to GND, I _S = 4 mA V _{IN} = V _{IH} I _S = 8 mA I _S = 24 mA I _S = 32 mA	1.65 2.3 3.0 4.5	1.2 1.3 1.5 2.0	1.2 1.3 1.5 2.0	1.2 1.3 1.5 2.0	Ω
R _{FLAT}		V _{IS} = V _{CC} to GND I _S = 4 mA I _S = 8 mA I _S = 24 mA I _S = 32 mA	1.65 2.3 3.0 4.5	240 60 14 5.0	240 60 14 5.0	240 60 14 5.0	Ω
I _{NO(OFF)}	Off Leakage Current	V _{IN} = V _{IL} V _{NO} = 1.0 V, V _{COM} = 4.5 V or V _{COM} = 1.0 V and V _{NO} 4.5 V	5.5	1.0	10	100	nA
I _{COM(OFF)}	Off Leakage Current	V _{IN} = V _{IL} V _{NO} = 4.5 V or 1.0 V V _{COM} = 1.0 V or 4.5 V	5.5	1.0	10	100	nA

AC ELECTRICAL CHARACTERISTICS (Input t_r = t_f = 3.0 ns)

Symbol	Parameter	Test Conditions	Guaranteed Max Limit								Unit
			V _{CC} = 1.8 V ± 0.15 V		V _{CC} = 2.5 V ± 0.2 V		V _{CC} = 3.3 V ± 0.3 V		V _{CC} = 5.0 V ± 0.5 V		
			Min	Max	Min	Max	Min	Max	Min	Max	
t _{ON}	Output Enable Time		2.3	10	1.6	5.6	1.5	4.4	1.3	3.9	ns
t _{OFF}	Output Disable Time		2.5	10.5	1.2	6.9	2.0	7.2	1.1	6.3	ns
t _{PD}	Propagation Delay Time		-	0.55	-	0.5	-	0.35	-	0.25	ns

		Typical @ 25°C, V _{CC} = 5.0 V	Unit
C _{IN}	Maximum Input Capacitance, Select Input	3.0	pF
C _{NO1} or C _{NO2}	Analog I/O (Switch Off)	10	
C _{COM(OFF)}	Common I/O (Switch Off)	10	
C _{COM(ON)}	Feed-through (Switch Off)	10	

NL7WB66

ADDITIONAL APPLICATIONS CHARACTERISTICS (Voltage Reference to GND Unless Noted)

Symbol	Parameter	Condition	V _{CC} (V)	Typical 25°C	Unit
BW	Maximum On-Channel -3.0 dB Bandwidth or Minimum Frequency Response	V _{IS} = 0 dBm V _{IS} centered between V _{CC} and GND	2.0	102	MHz
			3.0	180	
			4.5	186	
V _{ONL}	Maximum Feed-Through On Loss	V _{IS} = 0 dBm @ 10 kHz V _{IS} centered between V _{CC} and GND	2.0	-2.2	dB
			3.0	-0.8	
			4.5	-0.4	
V _{ISO}	Off-Channel Isolation	f = 100 kHz V _{IS} = 1.0 V RMS V _{IS} centered between V _{CC} and GND	2.0	-73	dB
			3.0	-74	
			4.5	-75	
Q	Charge Injection Enable Input to Common I/O	V _{IS} = V _{CC} to GND, F _{IS} = 20 kHz t _r = t _f = 3.0 nS R _{IS} = 0 Ω, C _L = 100 pF	3.0	4.8	pC
			5.5	7.5	
THD	Total Harmonic Distortion TDH + Noise	F _{IS} = 10 Hz to 100 kHz, R _L = R _{gen} = 600 Ω, C _L = 50 pF V _{IS} = 3.0 V _{PP} Sine Wave V _{IS} = 5.0 V _{PP} Sine Wave	3.0	0.19	%
			5.5	0.06	

DEVICE ORDERING INFORMATION

Device Order Number	Package	Shipping†
NL7WB66USG	US8 (Pb-Free)	3000 Units / Tape & Reel

†For information on tape and reel specifications, including part orientation and tape sizes, please refer to our Tape and Reel Packaging Specifications Brochure, BRD8011/D.

TIMING INFORMATION

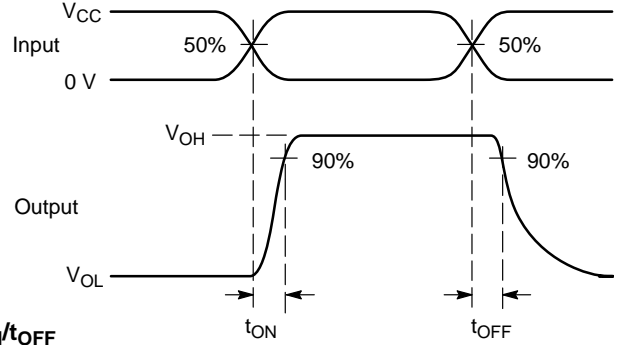
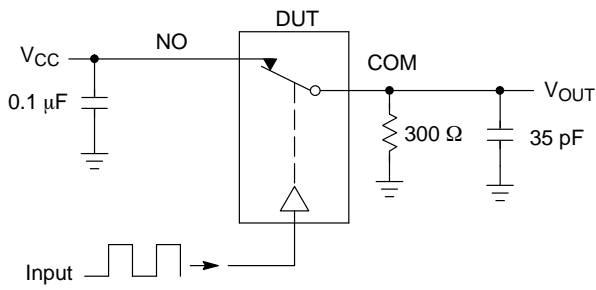

Figure 3. t_{ON}/t_{OFF}

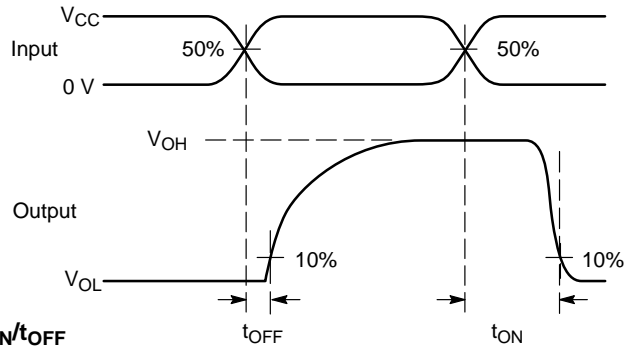
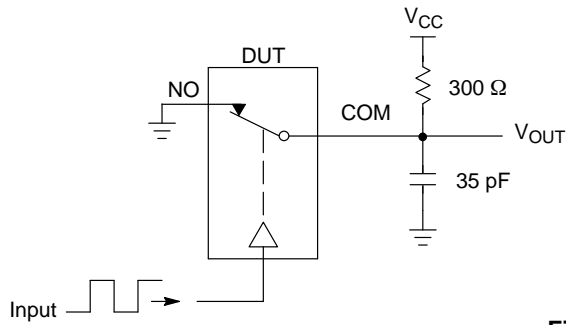
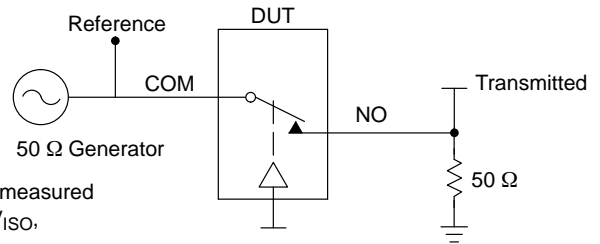

Figure 4. t_{ON}/t_{OFF}



Channel switch control/s test socket is normalized. Off isolation is measured across an off channel. On loss is the bandwidth of an On switch. V_{ISO} , Bandwidth and V_{ONL} are independent of the input signal direction.

$$V_{ISO} = \text{Off Channel Isolation} = 20 \text{ Log} \left(\frac{V_{OUT}}{V_{IN}} \right) \text{ for } V_{IN} \text{ at } 100 \text{ kHz}$$

$$V_{ONL} = \text{On Channel Loss} = 20 \text{ Log} \left(\frac{V_{OUT}}{V_{IN}} \right) \text{ for } V_{IN} \text{ at } 100 \text{ kHz to } 50 \text{ MHz}$$

Bandwidth (BW) = the frequency 3 dB below V_{ONL}

Figure 5. Off Channel Isolation/On Channel Loss (BW)/Crosstalk (On Channel to Off Channel)/ V_{ONL}

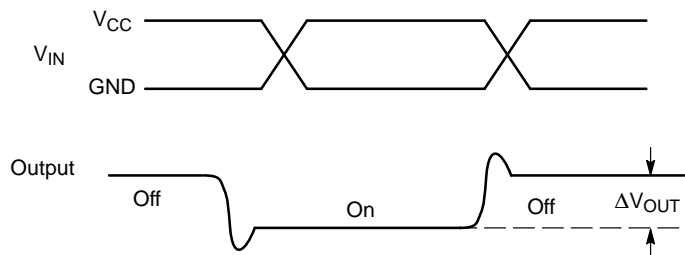
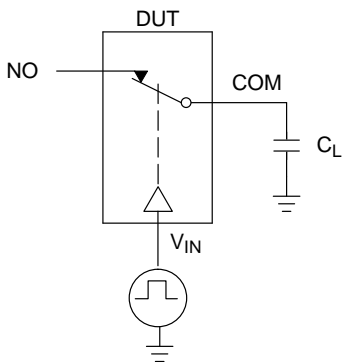
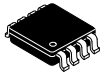

Figure 6. Charge Injection: (Q)

MECHANICAL CASE OUTLINE

PACKAGE DIMENSIONS

ON Semiconductor®



SCALE 4:1

US8
CASE 493
ISSUE D

DATE 15 JUL 2015

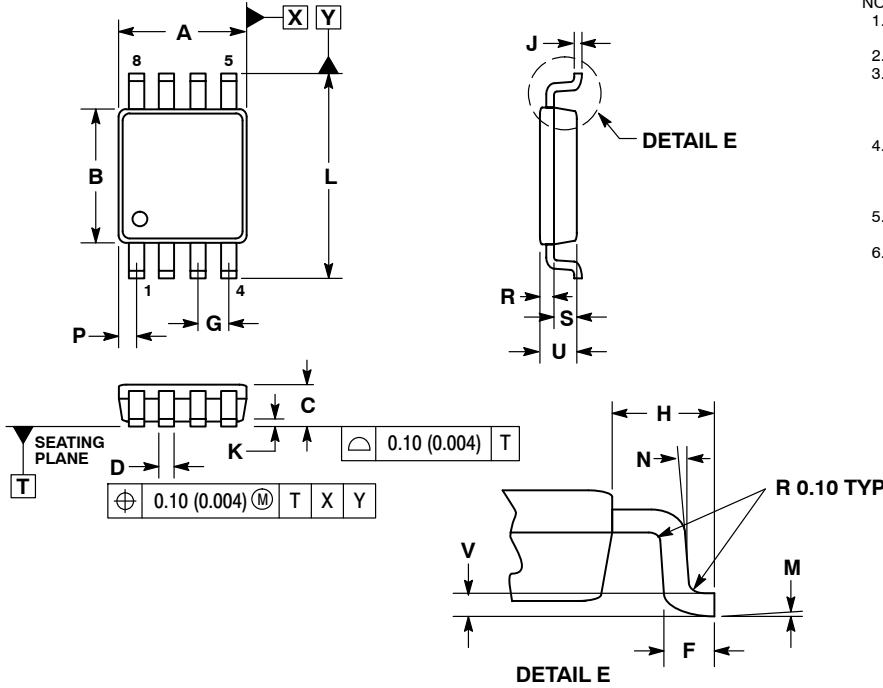

NOTES:

1. DIMENSIONING AND TOLERANCING PER ANSI Y14.5M, 1982.
2. CONTROLLING DIMENSION: MILLIMETERS.
3. DIMENSION A DOES NOT INCLUDE MOLD FLASH, PROTRUSION OR GATE BURR. MOLD FLASH, PROTRUSION AND GATE BURR SHALL NOT EXCEED 0.14MM (0.0055") PER SIDE.
4. DIMENSION B DOES NOT INCLUDE INTERLEAD FLASH OR PROTRUSION. INTERLEAD FLASH AND PROTRUSION SHALL NOT EXCEED 0.14MM (0.0055") PER SIDE.
5. LEAD FINISH IS SOLDER PLATING WITH THICKNESS OF 0.0076-0.0203MM (0.003-0.008").
6. ALL TOLERANCE UNLESS OTHERWISE SPECIFIED ±0.0508MM (0.002").

DIM	MILLIMETERS		INCHES	
	MIN	MAX	MIN	MAX
A	1.90	2.10	0.075	0.083
B	2.20	2.40	0.087	0.094
C	0.60	0.90	0.024	0.035
D	0.17	0.25	0.007	0.010
F	0.20	0.35	0.008	0.014
G	0.50 BSC		0.020 BSC	
H	0.40 REF		0.016 REF	
J	0.10	0.18	0.004	0.007
K	0.00	0.10	0.000	0.004
L	3.00	3.20	0.118	0.128
M	0°	6°	0°	6°
N	0°	10°	0°	10°
P	0.23	0.34	0.010	0.013
R	0.23	0.33	0.009	0.013
S	0.37	0.47	0.015	0.019
U	0.60	0.80	0.024	0.031
V	0.12 BSC		0.005 BSC	

RECOMMENDED
SOLDERING FOOTPRINT*

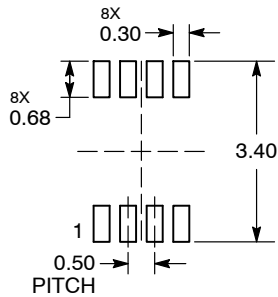

DIMENSIONS: MILLIMETERS

*For additional information on our Pb-Free strategy and soldering details, please download the ON Semiconductor Soldering and Mounting Techniques Reference Manual, SOLDERRM/D.

GENERIC
MARKING DIAGRAM*

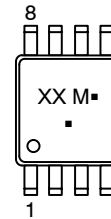

- XX = Specific Device Code
- M = Date Code
- = Pb-Free Package

(Note: Microdot may be in either location)

*This information is generic. Please refer to device data sheet for actual part marking.

DOCUMENT NUMBER:	98AON04475D	Electronic versions are uncontrolled except when accessed directly from the Document Repository. Printed versions are uncontrolled except when stamped "CONTROLLED COPY" in red.
DESCRIPTION:	US8	PAGE 1 OF 1

ON Semiconductor and ON are trademarks of Semiconductor Components Industries, LLC dba ON Semiconductor or its subsidiaries in the United States and/or other countries. ON Semiconductor reserves the right to make changes without further notice to any products herein. ON Semiconductor makes no warranty, representation or guarantee regarding the suitability of its products for any particular purpose, nor does ON Semiconductor assume any liability arising out of the application or use of any product or circuit, and specifically disclaims any and all liability, including without limitation special, consequential or incidental damages. ON Semiconductor does not convey any license under its patent rights nor the rights of others.

ON Semiconductor and  are trademarks of Semiconductor Components Industries, LLC dba ON Semiconductor or its subsidiaries in the United States and/or other countries. ON Semiconductor owns the rights to a number of patents, trademarks, copyrights, trade secrets, and other intellectual property. A listing of ON Semiconductor's product/patent coverage may be accessed at www.onsemi.com/site/pdf/Patent-Marking.pdf. ON Semiconductor reserves the right to make changes without further notice to any products herein. ON Semiconductor makes no warranty, representation or guarantee regarding the suitability of its products for any particular purpose, nor does ON Semiconductor assume any liability arising out of the application or use of any product or circuit, and specifically disclaims any and all liability, including without limitation special, consequential or incidental damages. Buyer is responsible for its products and applications using ON Semiconductor products, including compliance with all laws, regulations and safety requirements or standards, regardless of any support or applications information provided by ON Semiconductor. "Typical" parameters which may be provided in ON Semiconductor data sheets and/or specifications can and do vary in different applications and actual performance may vary over time. All operating parameters, including "Typicals" must be validated for each customer application by customer's technical experts. ON Semiconductor does not convey any license under its patent rights nor the rights of others. ON Semiconductor products are not designed, intended, or authorized for use as a critical component in life support systems or any FDA Class 3 medical devices or medical devices with a same or similar classification in a foreign jurisdiction or any devices intended for implantation in the human body. Should Buyer purchase or use ON Semiconductor products for any such unintended or unauthorized application, Buyer shall indemnify and hold ON Semiconductor and its officers, employees, subsidiaries, affiliates, and distributors harmless against all claims, costs, damages, and expenses, and reasonable attorney fees arising out of, directly or indirectly, any claim of personal injury or death associated with such unintended or unauthorized use, even if such claim alleges that ON Semiconductor was negligent regarding the design or manufacture of the part. ON Semiconductor is an Equal Opportunity/Affirmative Action Employer. This literature is subject to all applicable copyright laws and is not for resale in any manner.

PUBLICATION ORDERING INFORMATION

LITERATURE FULFILLMENT:

Email Requests to: orderlit@onsemi.com

ON Semiconductor Website: www.onsemi.com

TECHNICAL SUPPORT

North American Technical Support:
Voice Mail: 1 800-282-9855 Toll Free USA/Canada
Phone: 011 421 33 790 2910

Europe, Middle East and Africa Technical Support:

Phone: 00421 33 790 2910

For additional information, please contact your local Sales Representative