

REVISION RECORD				
REV	ECN	DESCRIPTION	DRFT	DATE

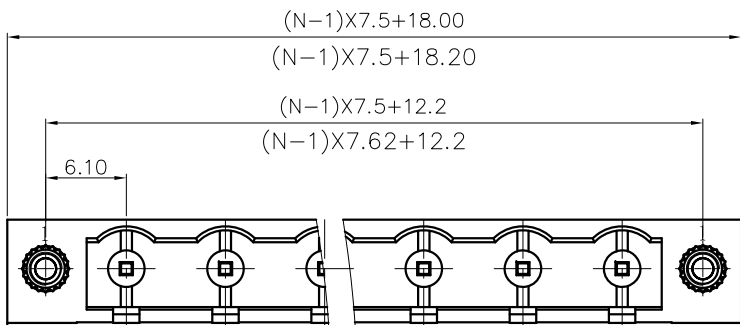

NOTES1:  
 UL Standard  
 1. Rated voltage/current : 300V / 15A  
 2. Withstanding voltage : AC1600V/1Min.

IEC Standard

Pollution degree	2
Overtoltage category	III
Rate impulse voltage(KV)	4.0KV
Rate voltage(V)	400V
Rate current(A)	20A

NOTES2:  
 1. Dimension shall be interpreted per ASME Y14.5-2009  
 2. Pitch : 7.5/7.62mm, Poles : N=02~12P  
 3. Operating temperature: -40°C~+105°C  
 4. Undimensioned tolerances:

Pitch range in mm	Nominal dimension range in mm							0.1/10	
	Over 6 TO 10	Over 10 TO 24	Over 30 TO 60	Over 60 TO 100	Over 100 TO 150	Over 150			
	±0.15	±0.20	±0.30	±0.30	±0.50	±0.70	±1.00	±1.30	±2'

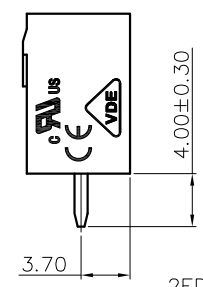
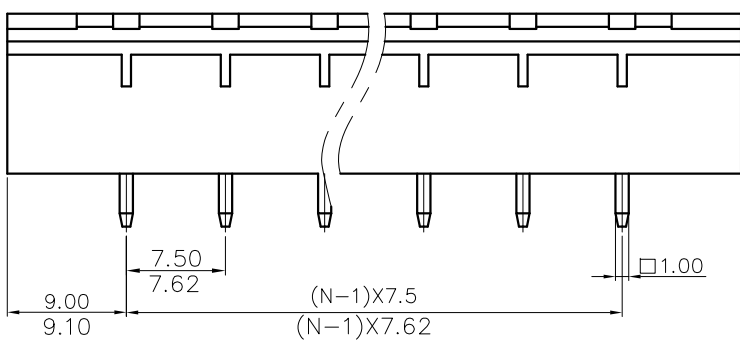
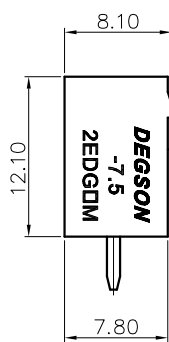

2EDGVM - 7.5/7.62- XXP - 1Y - 00A (H)  
 (Series No.) (Pitch) (Poles) (Single Pitch) (Color) : 1.(Grey)  
 2. (Blue)  
 3. (Black)  
 4. (Green)  
 5. (Orange)  
 6. (Red)  
 7. (Transparent)  
 8. (Yellow)  
 9. (White)  
 (RoHS)  
 00A- (Standard)

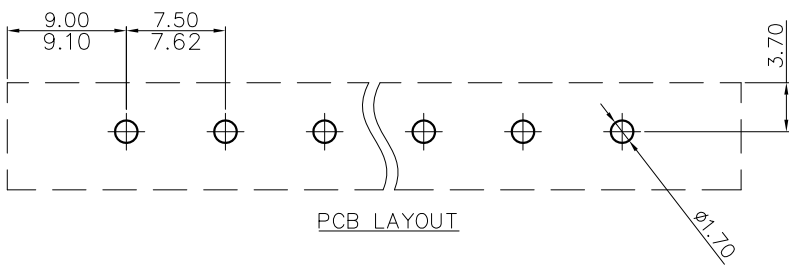

DETACHED LISTS	PART NO.:	NINGBO DEGSON ELECTRICAL CO., LTD			
	APPD:	NAME: 2EDGVM-7.5/7.62-XXP-1Y-00A(H)			
	CHKD:	TITLE: CUSTOMER DRAWING			
	DRFT:	DRAWING NO.:		REV	DO
	THIRD ANGLE PROJECTION		MM (INCH)	DO NOT SCALE DRAWING	SCALE 1:1