

SPECIFICATION FOR APPROVAL

客户名称

Customer: _____

品名

I 类径向引线独石电容器

Part Name: _____

客户料号

Customer Part No: _____

承认规格

Approve Item: CC4-

供应商料号

Part Number : _____

日期

2021-10-28

Date: _____

客户承认

Customer approval

供应商承认

Supplier admit that



规格目录中所列的产品，材料和尺寸其他内容如有更改，恕不另行通知。

Specifications of products, materials and dimensions listed in the specification catalog are subject to change without prior notice.

Featur

e

*

Miniature size, large capacitance, tape and reel packaging suitable for auto-placement

*

Epoxy resin coating creates excellent performance in humidity resistance, mechanical strength and heat resistance

*

Standard size, various lead configuration

Dielectric Type	Class I	Class II		
Dielectric Material	Temperature Compensating	X7R/X5R(B)	Z5U(E)	Y5V(Y/F)
Electrical Properties	The electrical properties is the most stable one and has little change with temperature, voltage and time.	X7R material has high dielectric constant, and its capacitance is higher than class I. These capacitors are classified as having a semi-stable T.C..	Temperature characteristic is between that of X7R and Y5V. The capacitance is unstable and sensible to temperature and voltage.	Y5V material has highest dielectric constant. Its capacitance and dissipation is sensible to temperature and voltage.
Application	Used in applications where low-losses and high-stability are required, such as filters, oscillators, and timing circuits so on.	Used over a wide temperature range , such in these kinds of circuits, DC-blocking, coupling, bypassing, frequency discriminating etc.	Ideally suited for bypassing and coupling application circuits operating with low DC bias in the environment approaching to room temperature.	Used over a moderate temperature range in application where high capacitance is required.
Available capacitance range	0.5pF~0.1uF	100pF~22uF	1nF~10uF	

Ordering Code

CT4 - 0805 B 104 K 500 P F3
 ↑ ↑ ↑ ↑ ↑ ↑ ↑ ↑
 A B C D E F G H B:

A:

Product Type	
CC4	Class I Dielectric Radial Leded MLCC
CT4	Class II Dielectric Radial Leded MLCC

Unit: inches

Nominal Body Size (Length × Width)			
0805	0.17 × 0.15	1812	0.34 × 0.26
1206	0.20 × 0.18	2225	0.41 × 0.37
1210	0.20 × 0.22	3035	0.50 × 0.41

C:

Temperature Characteristics			
CG	C0G	0 ± 30ppm/°C	-55~+125 °C
N	NP0		
B	X7R	±15%	-55~+125 °C
Y/F	Y5V	-80%~+30%	-25~+85 °C
E	Z5U	-56%~+22%	+10~+85 °C

D:

Nominal Capacitance
First two digits are significant, and the third digit is number of zer
For example:
104=100000pF 5R6=5.6pF

E:

Tolerance			
C	±0.25pF	K	±10%
D	±0.5pF	M	±20%
J	±5.0%	Z	-20~+80%

F:

Rated Voltage
First two digits are significant, and the third digit is number of zero.
For example:
500=50V; 101=100V

G:

Packaging Style		
P	Ammo	Tape
T	Reel	
Blank	Bulk	

H:

Lead Space (Unit: mm)			
F1	2.54	F4	7.50
F2	4.57	F5	3.50
F3	5.08		

Size Code and Voltage VS Capacitance

Size Code	Shape	Dimensions (Unit: mm)					Voltage	Available Capacitance Range		
		F ±0.5	H ±1	L Max	W Max	T Max		C0G (NP0)	X7R	Y5V/ Z5U
0805	a	2.54/3.50	5							
	b	2.54	10				25	0R5~272	101~224	102~125
	C1	5.08	5/10	4.0	3.8	3.8	50	0R5~222	101~104	102~105
	C2	5.08	5				100	0R5~102	101~333	102~104
	C3	5.08	5/10							
1206	a	2.54					25	0R5~562	101~107	101~107
	b	3.50	10	5.5	4.5	3.8	50	0R5~472	101~106	101~106
	C1	5.08					100	0R5~332	101~105	101~105
1210	b	3.50					25	100~103	471~105	472~155
	C1	5.08	10	5.5	5.5	3.8	50	100~752	471~105	472~155
		100						5R0~472	101~224	102~824
1812	b						25	100~153	471~335	103~335
		4.57	10	8.5	6.5	3.8	50	100~103	471~225	103~225
							100	5R0~103	101~334	103~105
2225	b						25	100~473	102~475	103~475
		5.50	10	10.5	9.5	4.2	50	100~273	102~335	103~335
							100	5R0~273	101~105	103~205
3035	b						25	100~104	102~226	103~106
		7.50	10	12.5	10.5	4.2	50	100~473	102~106	103~685

- Others are available, Contact Xingtai .

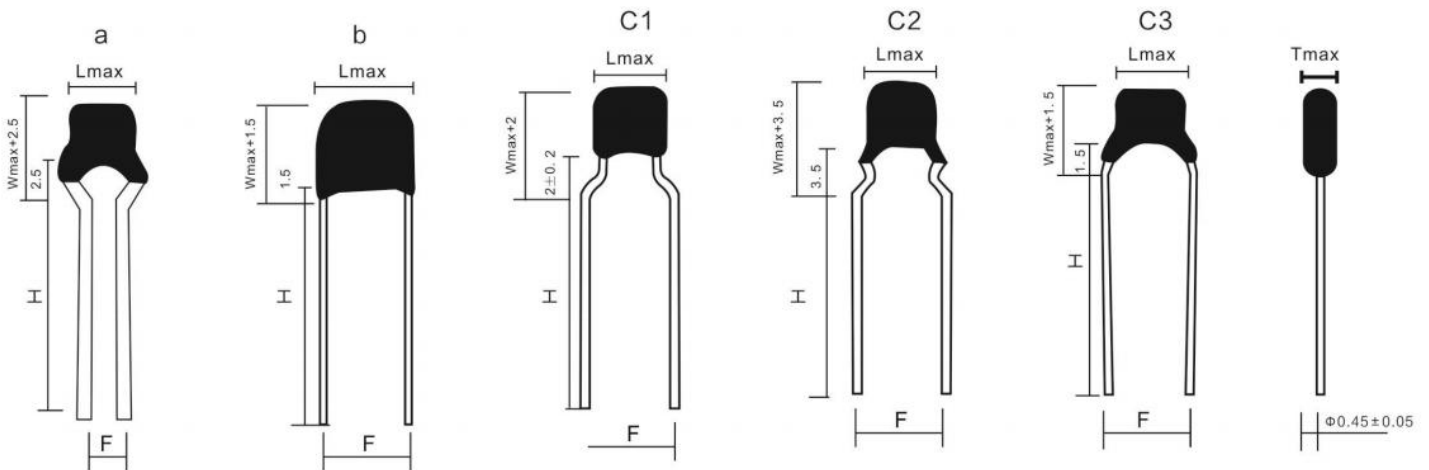

Reliability and Test Method for General Leaded MLCC

Item	Technical Specification		Test Method and Remarks				
Capacitance (C)	Class I	within the specified tolerance.	Capacitance	Measuring Frequency	Measuring Voltage		
			$\leq 1000\text{pF}$	$1\text{MHZ} \pm 10\%$	$1.0 \pm 0.2\text{V}$		
			$> 1000\text{pF}$	$1\text{KHZ} \pm 10\%$			
	Class II	within the specified tolerance.	The capacitance should be pretreated before measured(only for class II).				
			Measuring Frequency		Measuring Voltage		
$< 10\mu\text{F}$ $1\text{KHZ} \pm 10\%$ $\geq 10\mu\text{F}$ $120\text{Hz} \pm 10\%$			B: $1.0 \pm 0.2\text{V}$	E/ Y (F) $0.3 \pm 0.2\text{V}$			
Dissipation Factor (DF)	Class I	$C_R \geq 50\text{pF}$ $DF \leq 0.15\% C_R$		Capacitance	Measuring Frequency	Measuring Voltage	
		$< 50\text{pF}$ $DF \leq 1.5[(150/C_R)+7] \times 10^{-4}$		$\leq 1000\text{pF}$	$100\text{KHZ} \pm 10\%$	$1.0 \pm 0.2\text{V}$	
				$> 1000 \text{ pF}$	$100\text{KHZ} \pm 10\%$		
	II Class II	B	$DF \leq 3.5\%$		$< 10: 1\text{KHZ} \pm 10\%; 1.0 \pm 0.2\text{V}$ $\geq 10\mu\text{F} : 120\text{KHZ} \pm 10\%; 1.0 \pm 0.2\text{V}$		
		E/ Y (F)	$\leq 7.5\% (C_R \leq 0.1\mu\text{F})$ $\leq 10.0\%$ $(1\mu\text{F} > C_R > 0.1\mu\text{F})$ $\leq 15\% (C_R \geq 1\mu\text{F})$		$: 1\text{KHZ} \pm 10\%$ Measuring Frequency $0.3 \pm 0.2\text{V}$ Measuring Voltage		
Insulation Resistance	Class I	$C \leq 10\text{nF}$ $IR \geq 10000\text{M}\Omega$ $C > 10\text{nF}$ $R.C \geq 100 \text{ S}$		Measuring Voltage: Rated Volta 间: 60 ± 5 Duration: $60 \pm 5\text{s}$			
	Class II	$C \leq 25\text{nF}$ $IR \geq 4000\text{M}\Omega$ $C > 25\text{nF}$ $R.C \geq 100 \text{ S}$					

Item	Technical Specification	Test Method and Remarks	
Withstandi- ng Voltage	No breakdown or damage.	间Between terminals: Measuring Voltage : 间: 5 ± 1 I :300% Class I :300% Duration: $5 \pm 1s$ Rated voltage II :250% Class II :250% Rated voltage 50mA The charge/ discharge current is less than 50mA.	
		间Between terminals and body: $2.5U_R$: 1~5s Voltage: 2.5 times rated voltage Duration: 1~5s Small metallic ball method 1mm, 但保留距端头处2mm的的本体不插入。试验电压施加在短路回路端子和金属小球之间。 Small metallic balls with 1mm diameters shall be put in a vessel and the test capacitor shall be submerged except 2mm from the top of its component body and the terminals. The test voltage shall be applied between the short-circuited terminals and the metallic balls.	
Solder ability	75% Lead wire shall be at least 75% covered with a new solder coating.	将电容器引线浸入含有25%松香的酒精溶液中, 然后浸入温度为: $230 \pm 5^\circ\text{C}$ 的金属焊锡中 2 ± 0.5 秒, 注意: 电容器本体底面距离锡面约1.5~2mm, The terminal of capacitor is dipping into a 25% rosin solution of ethanol and then into molten solder of $230 \pm 5^\circ\text{C}$ for $2 \pm 0.5s$. In both cases the depth of dipping is up to about 1.5~2mm from the terminal body.	
Resistance to Soldering Heat	Item	$\Delta C/C \leq$	锡温: $270 \pm 5^\circ\text{C}$ 时间: $10 \pm 1s$ Solder temperature: $260 \pm 5^\circ\text{C}$ Duration: $10 \pm 1s$ 浸入条件: 将电容器插入厚度为1.6mm, 孔径为1.0mm的PC板。 Immersed conditions: Inserted into the PC board (with $t=1.6\text{mm}$, hole=1.0mm diameter) 对于I类介质, 试验后, 应在标准条件下恢复4~24小时后才测试。 Recovery: For class I, 4 to 24 hours of recovery under the standard condition after test. 对于II类介质, 在试验前应先进行如下预处理: $150(-10,+0)^\circ\text{C}$, 1小时, 接着在标准条件下恢复 48 ± 4 小时。 Preconditioning (Class II) : 1 hour of preconditioning at $150(-10,+0)^\circ\text{C}$, followed by 48 ± 4 hours of recovery under the standard condition. 恢复: 对于II类介质试验后, 应在标准条件下恢复 48 ± 4 小时后才测试。 Recovery (Class II) : 48 ± 4 hours of recovery under the standard condition after test.
	Class I	$\pm 2.5\%$ or $\pm 0.25\text{pF}$	
	B	$\pm 10\%$	
	E / Y(F)	$\pm 20\%$	

Item	Technical Specification	Test Method and Remarks			
High Temperature Loading Test	外观无可见损伤 No significant abnormality in appearance.	温度Temperature			
	容量变化Capacitance Change: I类介质Class I: ≤ ±3% or ±1pF 取较大值Whichever is larger. II类介质Class II: B: ≤ ±20% E / F(Y): ≤ ±30%	CG (N) /	X7R	Y5V	Z5U
		125(-0,+3)°C		85(-0,+3) °C	
	Dissipation Factor: I类介质: 小于原始值的1.5倍 Class I: Not more than twice of initial value. II类介质Class II: B: ≤ 5.0% E / F(Y): ≤12.5% (C _R ≤ 0.1uF) ≤15.0%(1uF > C _R > 0.1uF) ≤17.5% (C _R ≥ 1uF)	电压: 1.5倍额定电压 Applied voltage: 1.5 times rated voltage 充放电流不超过50mA The charge/ discharge current is less than 50mA. 时间: 100 (-0, +24) 小时 Duration: 100 (-0, +24) hours 恢复时间: Recovery Time: 24 ±2小时, 24 ±2 hours			
绝缘电阻Insulation Resistance: ≥ 2000MΩ or 50 Ω.F 取较小值Whichever is smaller.					
Solvent Resistance	外观无可见损伤或异常,标记清晰。 No defects or abnormalities in appearance and legible marking.	溶剂温度: 23 ± 5°C Solvent temperature: 将样品浸在溶剂中1分钟, 用脱脂棉在样品有标志部位刷10次, 重复3次。 put the sample into solvent 1 Min, and then take it out and brush sample' s notation area 10 times with pledget , repeat 3 times.			

以上所示“标准条件”解释如下:

温度: 5~35°C, 湿度: 45~85%, 气压: 86~106kPa

* Note on standard condition: " standard condition " referred to herein should be defined as follows:

5 to 35°C of temperature, 45 to 75% of relative humidity, and 86 to 106kPa of atmospheric pressure.

若测试结果有争议时, 仲裁试验用标准大气条件为:

温度: 25 ± 1°C, 相对湿度: 48%~52%, 气压: 86~106kPa

* When there are questions concerning measurement results:

In order to provide correlation data, the test should be conducted under a condition of 25 degrees plus/minus 1 centigrade of temperature, 48% through 52% of relative humidity and 86 through 106 kPa of atmospheric pressure.

Packaging Style

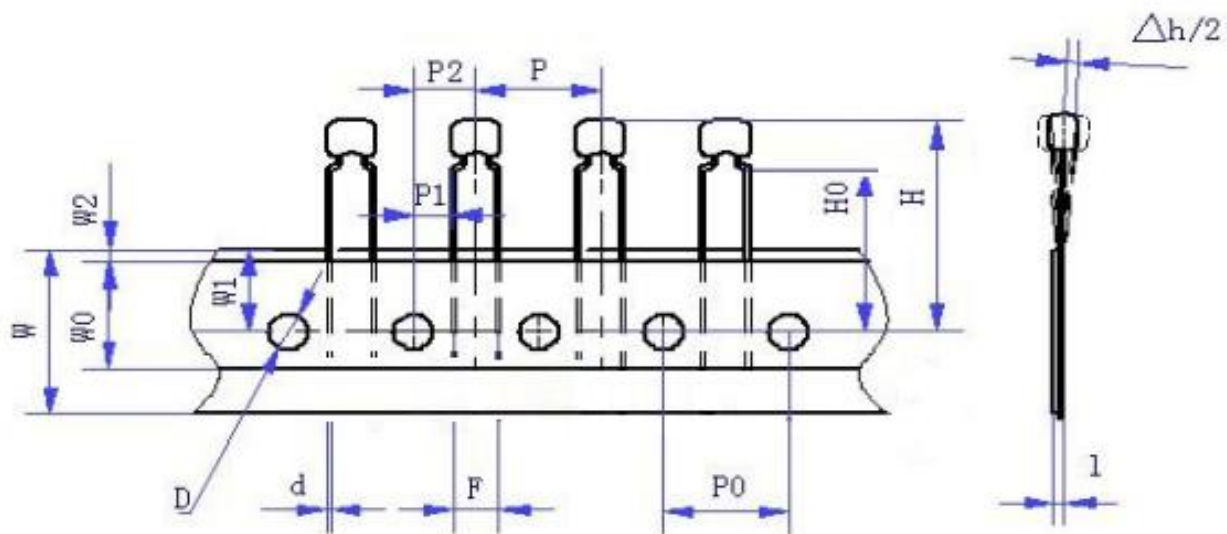

Code	P	P0	P1	P2	d	Δh	W	W0	W1	W2	H	H0	D	t
Dim.	12.7	12.7	3.75 5.1	6.35	0.5	0	18	8	9	1.5	34.25	17	4.0	0.7
Tol.	±0.2	±0.2	0.7	±1.3	±0.1	±2	±0.8	±1	±0.5	±1.5	Max.	±0.5	±0.2	Max.

Note:

P1=3.85mm for F=5.08mm; P1=5.1mm for F=2.54mm.

Ammo Packaging

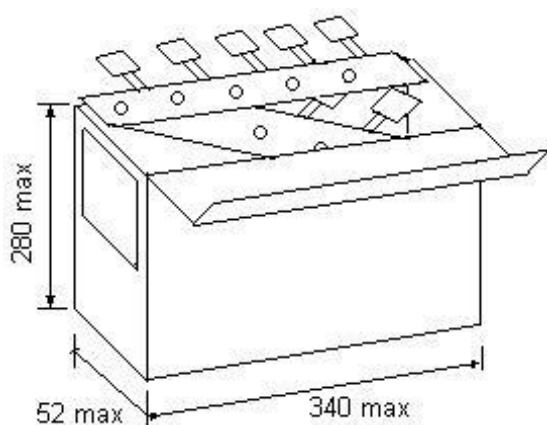

Tape and Reel Packaging

