

深圳市福浪电子有限公司  
FRONTER ELECTRONICS CO., LTD.

**APPROVAL  
SHEET**



CUSTOMER: TRIATRON LTD

DESCRIPTION: HC-49/S 4.000MHz Quartz Crystal Resonator

MANUFACTURER PART NO.: FTX4.000M16S-30/30DFF69

CUSTOMER PART NO: \_\_\_\_\_

USED IN MODEL: \_\_\_\_\_

REVISION A1

承 认 APPROVAL		
工程部 TECHNOLOGY DEPT.	品质部 QUALITY DEPT.	采购部 PURCHASING DEPT.

Date: August 19, 2024



深圳市福浪电子有限公司  
FRONTER ELECTRONICS CO., LTD

<u>Rev</u>	<u>Revise page</u>	<u>Revise contents</u>	<u>Date</u>	<u>Ref.No.</u>	<u>Reviser</u>
A1	ALL	Initial released	2024.08.19	N/A	DavidJiang

TPWATRPOFF

<b>FRONTER ELECTRONICS CO., LTD.</b>		
<b>DESCRIPTION</b>	HC-49/S 4.000MHz ±30ppm 16pF	<b>Page:</b>
<b>DATE</b>	2024-08-19	2 / 6

# 1. QUARTZ CRYSTAL UNIT SPECIFICATION

Parameter	Specification
1.1 Frequency:	4.000MHz
1.2 Mode of Oscillation	AT Fundamental
1.3 Holder type :	HC-49/S
1.4 Frequency tolerance:	±30ppm at 25°C
1.5. Equivalent resistance (Rr):	120Ω max.
1.6 Operating temperature range:	-40°C To +85°C
1.7 Storage temperature range:	-55°C To +125°C
1.8. Frequency stability:	±30ppm at -40°C To +85°C
1.9 Loading capacitance (CL) :	16pF
1.10 Drive level (DL):	100 uW Typical
1.11 Shunt Capacitance (C0):	7.0pF max.
1.12 Insulation resistance (IR) :	More than 500M ohms at DC 100V
1.13 Circuit:	Measured in S&A 250B
1.14 Aging:	±3 ppm max.(+25°C 1 <sup>st</sup> Year)
1.15 Dimensions and marking	Refer to page.4
1.16 Other	RoHS Compliant (Pb free)

**Standard atmospheric conditions**

Unless otherwise specified, the standard range of atmospheric conditions for making measurement and tests are as follow:

Ambient temperature : 25±3°C

Relative humidity : 40%~70%

<b>FRONTER ELECTRONICS CO., LTD.</b>		
<b>DESCRIPTION</b>	HC-49/S 4.000MHz ±30ppm 16pF	<b>Page:</b>
<b>DATE</b>	2024-08-19	3 / 6

## 2. MARKING & DIMENSIONS

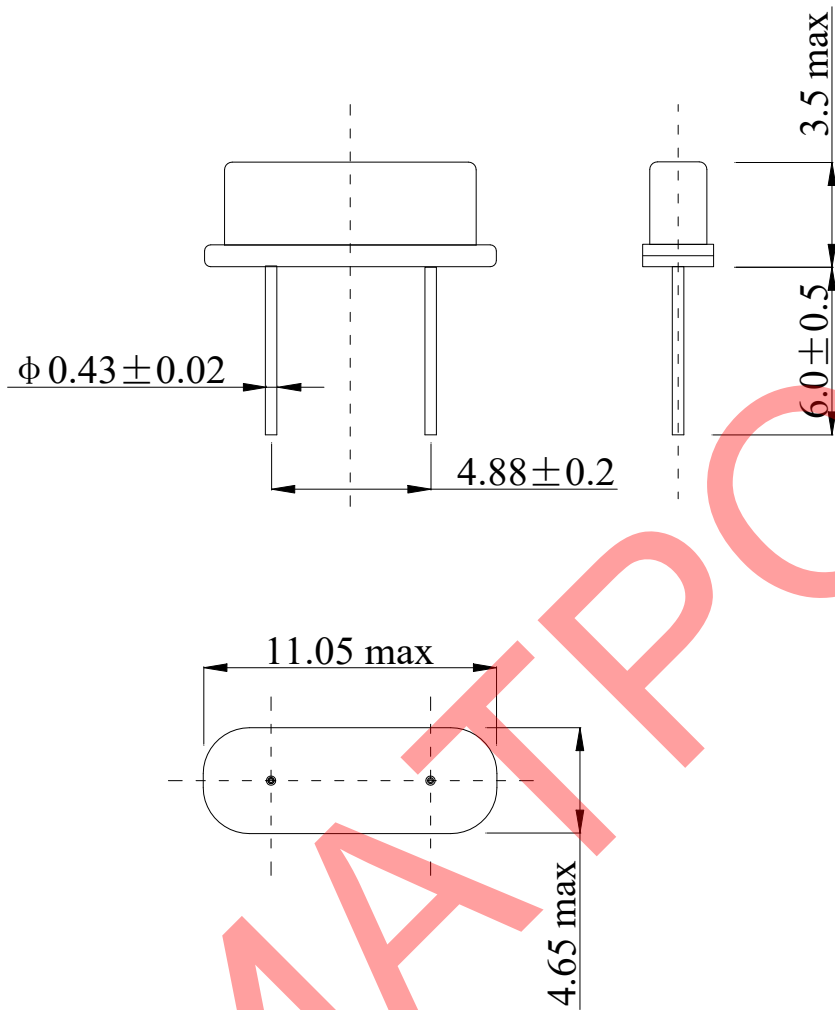

\*Marking should be printed as following:

Logo, Nominal Frequency

Logo: T

Nominal Frequency: (ex. 12.000MHz → 12.000)

Marking: Laser marking

### FRONTER ELECTRONICS CO., LTD.

<b>DESCRIPTION</b>	HC-49/S 4.000MHz ±30ppm 16pF	Page:
<b>DATE</b>	2024-08-19	4 / 6

### 3.MECHANICAL/ENVIRONMENTAL CHARACTERISTICS

NO.	项 目 ITEM	条 件 CONDITIONS	规 格 SPECIFICATIONS
3.1	漏气试验 Leaking Test	完全浸入 90±3℃热水中 3 分钟。 Fully immersed into hot water at 90℃ ±3℃ for 3 minutes.	无气泡存在 no air bubble are visible.
3.2		用氦质谱仪测试或加压测绝缘电阻 Take measurements with a helium leakage detector, or measure insulation resistance under pressure.	$1 \times 10^{-8} \text{ Pa.m}^3 / \text{s}$ Max or $IR \geq 500M\Omega$
3.3	跌落试验 Drop Test	高度 75cm, 自由落体于 3cm 木板上, 6 次 Dropping 6 times from the height of 75 cm onto hard wooden board of thickness more than 30mm.	频率变化±5ppm 以内, 电阻变化 15%以内 The crystal must meet: $\Delta f \leq \pm 5 \text{ ppm}$ $\Delta R \leq 15\%$
3.4	振动试验 Vibration Test	频率 10~55Hz, 振幅 1.5mm, 时间 1.5 分钟循环, 在 XYZ 方向各 2 小时。 Vibration Frequency: 10~55Hz Cycle: 1.5 Min. Amplitude: 1.5mm P-P. Direction: X.Y.Z Time: 2 Hours / Each Direction	频率变化±5ppm 以内, 电阻变化 15%以内 The crystal must meet: $\Delta f \leq \pm 5 \text{ ppm}$ $\Delta R \leq 15\%$
3.5	可 焊 性 Solderability Test	从引线末端至距底部 2mm 处放入 230℃ ±5℃ 焊槽内,时间: 5±0.5 秒。 The terminal lead wire is to be soaked in a 230℃ ±5℃ tin trough for 5±0.5 seconds.	沾锡面 ≥90%. 频率变化±5ppm 以内,电阻变化 15%以内 Tin over the wire ≥90% The crystal must meet: $\Delta f \leq \pm 5 \text{ ppm}$ $\Delta R \leq 15\%$
3.6	耐低温性 Low Temperature Enduring	在 -40℃ ±3℃ 下,放置 96 小时,取出后在常温下恢复 2 小时。 The samples crystal is to be tested after being placed in the environment of -40℃ ±3℃ for 96 hours, and recovered to room temperature for 2 hours.	频率变化±5ppm 以内, 电阻变化 15%以内 The crystal must meet: $\Delta f \leq \pm 5 \text{ ppm}$ $\Delta R \leq 15\%$
3.7	耐高温性 High Temperature Enduring	在 +85℃ ±3℃ 下放置 96 小时,取出后在常温下恢复 2 小时。 The samples crystal is to be tested after being heated at +85℃ ±3℃ for 96 hours, and cooled to room temperature for 2 hours.	频率变化±5ppm 以内, 电阻变化 15%以内 The crystal must meet: $\Delta f \leq \pm 5 \text{ ppm}$ $\Delta R \leq 15\%$

#### FRONTER ELECTRONICS CO., LTD.

DESCRIPTION	HC-49/S 4.000MHz ±30ppm 16pF	Page:
DATE	2024-08-19	5 / 6

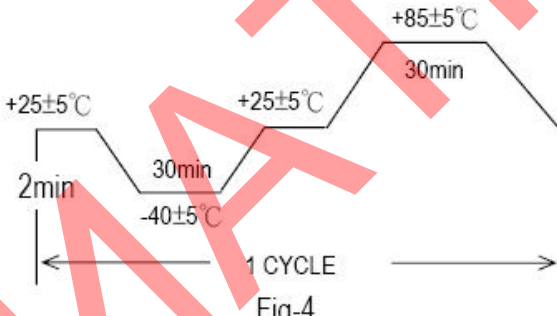
3.8	恒定湿热 Humidity	<p>在 <math>40\pm 3^{\circ}\text{C}</math>、RH <math>93\%\pm 2\%</math>下放置 96 小时,取出后恢复 2 小时。 The temperature is at <math>40\pm 3^{\circ}\text{C}</math>, and at <math>93\%\pm 2\%</math> RH after 96 hours, and cooled to room temperature for 2 hours.</p>	<p>外观无异常, 频率变化<math>\pm 5\text{ppm}</math> 以内, 电阻变化 15%以内 The crystal must meet: <math>\Delta f \leq \pm 5\text{ppm}</math> <math>\Delta R \leq 15\%</math></p>
3.9	耐焊接热 Resistance to Solder Heat	<p>引线端子应插入 <math>350\pm 5^{\circ}\text{C}</math>的焊接槽中 <math>3\pm 0.5</math> 秒或 <math>260\pm 5^{\circ}\text{C}</math>的焊接槽中 <math>10\pm 0.5</math> 秒,插入深度为从引线末端至距底部 2mm 处,而后放在自然环境中 1 小时,再进行测试。 Lead terminals are immersed up to 1.5mm from resonator's body in soldering bath of <math>350\pm 5^{\circ}\text{C}</math> for <math>3\pm 0.5</math> sec. And then resonator shall be measured after being placed in room temperature for 1 hour.</p>	<p>外观无异常, 频率变化<math>\pm 5\text{ppm}</math> 以内, 电阻变化 15%以内 The crystal must meet: <math>\Delta f \leq \pm 5\text{ppm}</math> <math>\Delta R \leq 15\%</math></p>
3.10	热冲击 Thermal shock	<p>在 <math>-40^{\circ}\text{C}</math> 保持 30 分钟, <math>+85^{\circ}\text{C}</math> 保持 30 分钟, 循环 10 次。 Should be satisfied after supplying the following temperature cycle ( 10 cycles). (Refer to Fig-4). Temperature shift from low to high, high to low shall be done in <math>1^{\circ}\text{C}/\text{min}</math>.</p> 	<p>外观无异常, 频率变化<math>\pm 5\text{ppm}</math> 以内, 电阻变化 15%以内 The crystal must meet: <math>\Delta f \leq \pm 5\text{ppm}</math> <math>\Delta R \leq 15\%</math></p>

## 4. PACKAGE 包装

### 4.1 Quantity of package:

<b>250</b> pieces of crystal unit	per bag
<b>2500</b> pieces of crystal unit	per inner box, 10 bags
<b>25000</b> pieces of crystal unit	per carton, 10 inner boxes

### FRONTER ELECTRONICS CO., LTD.

<b>DESCRIPTION</b>	HC-49/S 4.000MHz $\pm 30\text{ppm}$ 16pF	<b>Page:</b>
<b>DATE</b>	2024-08-19	6 / 6