

产品承认书

APPROVAL SHEET

客户 CUSTOMER	宜兴市元宏进出口有限公司
品名 PART NAME	铝电解电容器 Aluminum Electrolytic Capacitors
规格描述 DESCRIPTION	470 μ F 450 V 35X50 牛角(105°C 3000H)
编码 PART NO.	HHP470450M3550V
日期 DATE	2025-02-06
编号 NUMBER	YH4704503550

核准 APPROVED	审核 CHECKED	拟制 PREPARED
赵博	李真	李京夏

客户承认 CUSTOMER APPROVED
承认后请寄回一份 Please return one copy with your approval

SPECIFICATION		
SERIES	HP	Page 1

1、概述 SCOPE

本承认书规定了 HP 系列牛角引出铝电解电容器的技术规范。

This specification covers “HP series” Snap-in type aluminum electrolytic capacitors.

2、参考标准 APPLICABLE SPECIFICATION

本承认书参考 GB/T2693 和 GB/T5993 制定。

This approval sheet consulted the institute of GB/T2693 and GB/T5993

3、工作温度范围 OPERATING TEMPERATURE RANGE

工作温度范围是电容器在施加额定工作电压条件下，可以长期可靠工作的环境温度范围

-40℃~+105℃

Operating temperature range is the range of ambient temperature at which the capacitor can be operated continuously at rated voltage

-40℃~+105℃

4、测试环境 ATMOSPHERIC CONDITION OF MEASUREMENTS:

如果没有其他规定，标准的测试、检验环境条件如下所示：

环境温度：15 至 35℃

相对湿度：45 至 75%

大气压力：86kpa 至 106kpa

如果对测试结果有异议，可以在以下条件测试：

环境温度：25±2℃

相对湿度：60 至 70%

大气压力：86kpa 至 106kpa

Unless otherwise specified, the standard range of atmospheric conditions for making Measurements and tests are as follows

Ambient temperature :15 to 35℃

Relative humidity : 45 to 75%

Air pressure: 86kpa to 106kpa

If there may be doubt on the results, measurements shall be made within the following limits.

Ambient temperature :25 ±2℃

Relative humidity : 60 to 70%

Air pressure: 86kpa to 106kpa

5. 主要技术参数 Specifications

5.1 产品尺寸表

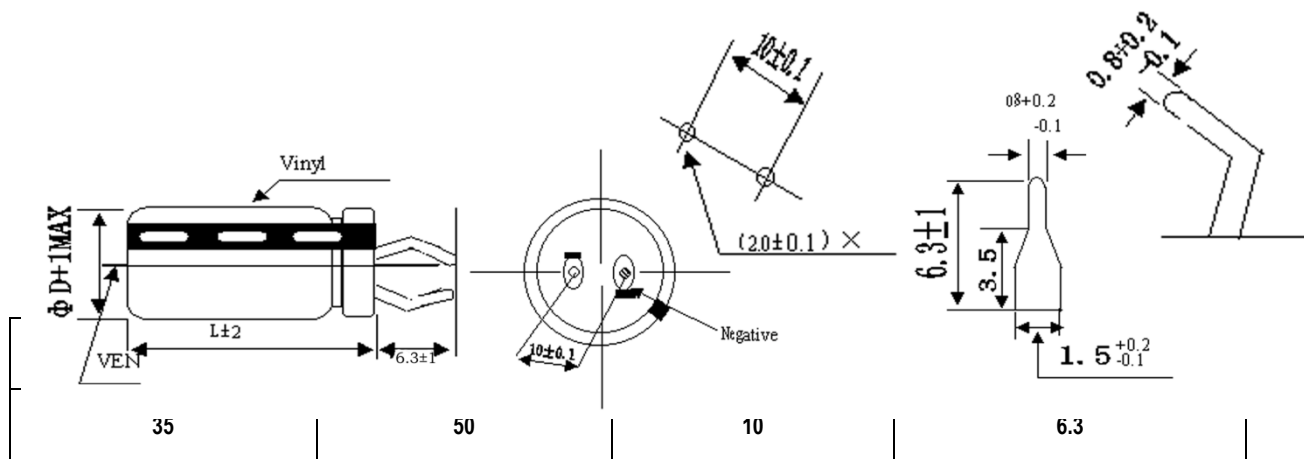

额定电压 WORKING VOLTAGE (V.DC)	静电容量 RATED CAP. (μ F)	容量许容差 CAP. TOLERANCE (%)	损耗角 正切值 TAN δ (MAX)	漏电流 LEAKAGE CURRENT (μ A MAX)	纹波电流 RIPPLE CURRENT (mA r.m.s)	阻抗值 IMPEDANCE (m Ω .MAX)	温度范围 OPERATING TEMPERATURE RANGE
450	470	-20~+20%	0.2	2115	2500	560	-40 ~ +105°C
	at 120Hz 20°C			after 2min	120 Hz 105°C	120K Hz 20°C	

5.2 技术参数

VV.(V.DC)	Capacitance (μ F)	60HZ	120HZ	1KHZ	10KHZ
315-500VV	ALL cap	0.77	1.00	1.3	1.41

5.3 频率补偿系数 Frequency correction factor for ripple current

		SPECIFICATION	
		SERIES	HP
		Page 3	

	项 目 Items	条 件 Conditions	规 格 Specifications
--	--------------	-------------------	-----------------------

6. Reliability Test:

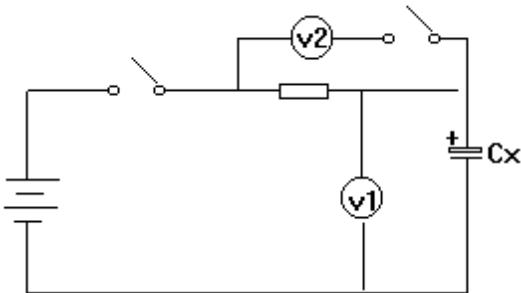
序号 NO	项目 Item	条 件 Conditions	规 格 Specifications
6.1	电容量 Capacitance	测试频率:120HZ±20% 测试电路:串联等效 测试电压:0.5Vrms 以下 Measuring frequency : 120HZ±20% Measuring circuit: Series equivalent circuit Measuring voltage: 0.5Vrms or less +1.5 to 2.0 VDC	静电容量允许偏差 -20~+20% Capacitance Tolerance -20~+20%
6.2	损耗角正切值 Dissipation Factor	测试条件与 5.2 电容量测试相同 Testing condition are the same as 5.1 for capacitance	Refer to table 1.
6.3	漏电流 Leakage current	<p>电容器接 1000±10Ω.的保护电阻施加电压 2 分钟后的测试电流。 The rated voltage shall be applied across the capacitor and its protective resistor which shall be 1000±10Ω.The leakage Current shall then be measured after an electrocution period of 2 min. The leakage current shall be calculated by the following equation. 漏电流: (I) =E/Rs Leakage current: E: 直流电压表的电压值 Voltage measured with DC voltmeter Rs:标准电阻的电阻值 Resistance of the protective resistor 测定电路 measurement circuit</p>  <p>电压降下法 voltage drop method) Rs:标准电阻的电阻值 (1000±10Ω) protective resistor 直流电压表或电子电压表 DC voltmeter or electronic voltmeter S1:开关 switch S2:电压表保护用变换开关 Protective switch for a voltmeter CX:待测电容器 test capacitance</p>	$I_C \leq 0.01CV + 10(\mu A)$ IC: 漏电流(μA) C: 容量(μF) V: 额定工作电压(V) $I_C \leq 0.01CV + 10(\mu A)$ IC: Leakage current(μA) C: Capacitance (μF) V: Rated voltage(V)

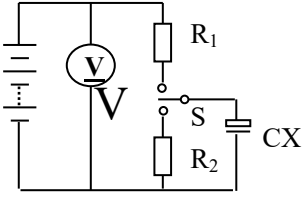
6.4	浪涌电压 Surge Voltage	在下面规定的温度下,通过指定的电压(见Table 6,table 1),SERIES (充电 30 秒,放电 5 分钟)为一周,往返 1000 回合,常温常湿下放置 1-2 小时达到热平衡状态测定满足 The capacitor shall be subjected to 1000 cycles at a temperature specified below, each consisting of a charge period of 30±5s, followed by a discharge period of approx 5min.30 s. And the capacitor shall be stored 1-2 hours under standard atmospheric conditions to obtain thermal stability , after which measurement shall be made 应加电压: 见 3 项 Test voltage: see 3 温度:15~30°C Test Temperature : 15~30°C 测试回路 Measurement circuit	漏电流: 不超过规定值 Leakage Current:4
		 <p>R1: 串联保护电阻 (1KΩ) Protective series resistor (1KΩ) V: 直流电压表 DC Voltage R2: 放电电阻 Discharge resistor (1KΩ) S: 切换开关 Switch Cx: 待测电容器 Test Capacitor</p>	Not more than the specified value 容量变化: 初始值的±15%以内 Capacitance change: Within ±15% of the initial value 损耗角正切: 不超过规定值 Dissipation Factor : Not more than the specified value
6.5	防爆试验 Safety vent Test	电容器上应加 1A 逆向直流电,防爆壳正常动作,无金属片飞散、起火、爆炸。 The capacitor is shall be connected in inverse polarity, and applied DC current at 1A constant, The pressure relief device shall open in such a way as to avoid any danger of fire or explosion of capacitor elements (Terminal and mental foil etc.) or cover	

NO.	项目 Items	条 件 Conditions
-----	-------------	-------------------

6.6 温度特性
Temperature
Characteristic

电容器根据下表的次序处理。
The capacitor shall be subjected in turn to the procedures specified below.

阶段	温度	时间
1	20±2℃	热平衡状态
2	-25℃	2h
3	20±2℃	热平衡状态
4	105℃	2h
5	20±2℃	热平衡状态

电容器放置在每一温度下，待阻抗或电容量稳定后方可测试。

* The capacitor should be stored at each temperature until measured impedance or capacitance are stabilized .

阶段 2 Step 2	阻抗比（对阶段 1） Impedance ratio	见表 1 (Page 6) refer to table 1
	静电容量变化率（对阶段 1） Change in capacitance	within -20~+20% of step 1
阶段 4 Step 4	静电容量变化率（对阶段 1） Change in capacitance	within -20~+20% of step 1

阶段 1：测定容量，损耗和阻抗值。

Step 1: Capacitance, Dissipation Factor and impedance shall be measured.

阶段 2：放置 2 小时后，达到热平衡状态再测。

Step 2 : After the capacitor being stored for 2 hours, Capacitance, Dissipation Factor and impedance shall be Measured. The measurement shall be made at thermal stability.

阶段 4：放置 2 小时后，达到热平衡状态再测。

Step 4 : After the capacitor being stored for 2 hours, Capacitance, Dissipation Factor and impedance shall be Measured. The measurement shall be made at thermal stability.

		SPECIFICATION	
		SERIES	HP
		Page 6	
No.	项目 Items	条 件 Conditions	规 格 Specifications
6.7	高温负荷 Load life	<p>在 105±2℃的恒温箱内，电容器施加最大允许纹波电流，施加直流电压和交流电压的峰值的和要等于额定电压，时间 5000 小时，试验结束后，在标准状态下放置 16 小时后进行测试。</p> <p>The capacitor shall be placed in a circulating air oven at an ambient temperature of 105±2℃。 It must not be subjected to direct radiation from heating elements. DC voltage and the rated ripple current shown in table shall be applied for a period of 10000 hours. The sum of the DC voltage and peak AC voltage must not exceed the full rated voltage of the capacitor. It shall be subjected to standard atmospheric for 16 hours, after which measurement shall be made.</p>	<p>漏电流：不超过规定值 容量变化：初测值的±30 % 以内 损耗角正切：不超过规定值的 3 倍</p> <p>Leakage current : Not more than Initial specified value Capacitance change : Within ±30 % of initial value dissipation factor : Not more than 300% of initial specified value</p>
6.8	高温存储 Shelf life	<p>在 105±2℃环境下无负荷贮存 1000 h，至少恢复 16 小时后。</p> <p>The capacitors are then stored with no voltage at a temperature of 105±2℃for 1000 h and then resumed 16 hours.</p>	<p>漏电流：不超过规定值的 2 倍 容量变化：初测值的±20 % 以内 损耗角正切：不超过规定值的 2 倍</p> <p>Leakage current : Not more than 200% of initial specified value Capacitance change : Within ±20 % of initial value dissipation factor : Not more than 200% of initial specified value</p>

序号	项目	条 件	规 格
----	----	-----	-----

		SPECIFICATION																							
		SERIES	HP	Page 7																					
NO	Item	Conditions			Specifications																				
6.9	可焊性 Solder ability	浸渍时间 Solder press time: 2.5±0.5s 焊接温度 Solder temperature: 255+5/-0℃			浸渍面积 90%以上附着 At least 90% of Circumferential surface of the dipped portion of termination shall be covered with new solder																				
6.10	端子强度 terminal Strength	端子抗拉强度: 沿电容器端子引线方向施加固定重力*1N 10 秒钟. <table border="1" data-bbox="432 663 1088 748"> <tr> <td>引线直径 Φ</td> <td>0.5</td> <td>0.6</td> <td>0.8</td> <td>1.0</td> </tr> <tr> <td>拉力 N</td> <td>5.0</td> <td>10</td> <td>20</td> <td></td> </tr> </table> 端子抗弯强度: 在电容器引线施加固定重力*2N,然后将电容体弯折 90°后回到原位。 上述过程在 5 秒内完成。 <table border="1" data-bbox="432 916 1088 1001"> <tr> <td>引线直径 Φ</td> <td>0.5</td> <td>0.6</td> <td>0.8</td> <td>1.0</td> </tr> <tr> <td>拉力 N</td> <td>5.0</td> <td>10</td> <td>20</td> <td></td> </tr> </table> Tensile strength of termination: A static load of* IN shall be applied to the terminal in the axial direction and acting in a direction away from the body for 10 sec. Bending strength of termination: Hang the specified dead weight of*2N,then bent the body through 90°with The same speed ,again return to the original position Carry out this operation in 5 sec.			引线直径 Φ	0.5	0.6	0.8	1.0	拉力 N	5.0	10	20		引线直径 Φ	0.5	0.6	0.8	1.0	拉力 N	5.0	10	20		测量静电容量时, 应无接触不良、开路或短路以及无可见机械损伤 When the capacitance is measured, there shall be no intermittent contacts or open –or short –circuiting . There shall be no such mechanical damage as terminal damage etc.
引线直径 Φ	0.5	0.6	0.8	1.0																					
拉力 N	5.0	10	20																						
引线直径 Φ	0.5	0.6	0.8	1.0																					
拉力 N	5.0	10	20																						
6.11	振动试验 Resistance to Vibration	依据 IEC60068-2-6 试验。 在 3 个互相垂直的方向分别施加 2 小时振动, 共 6 小时 To comply with IEC60068-2-6 Direction and duration of vibration: 3 orthogonal directions mutually each for 2h,Total 6h.			测量静电容量时, 应无接触不良、开路或短路以及无可见机械损伤 When the capacitance is measured, there shall be no intermittent contacts or open –or short –circuiting . There shall be no such mechanical damage as terminal damage etc.																				

		SPECIFICATION	
		SERIES	HP
		Page 8	
序号 NO	项目 Item	试验方法 Experiment method	特性 Performance
6.12	耐焊接热 Resistance to soldering heat	温度:270+2/-0°C Test Temperature: 270±5°C 时间:10±0.5 s Test time: 10±0.5s	容量变化:在初始值±10%范围内 损耗角正切值: 不超过规定值 漏电流: 不超过规定值 外观:无异状 Variation of capacitance: Within ±10% of the initial value Dissipation factor: Not more than the specified value. Leakage current: Not more than the specified value. Appearance: No remarkable abnormality.
6.13	稳态湿热 Resistance to damp heat (steady state)	依据 IEC60068-2-3 进行试验 试验温度: 40±2°C 试验时间: 240±8h 相对湿度: 90~95% 试验后, 电容器在标准大气条件下 1~2 小时, 然后测试参数 To comply with IEC60068-2-3 Test temperature: 40±2°C Test time : 240±8h Relative humidity: 90~95% After completion of test, the capacitor shall be subjected to standard atmospheric conditions for 1 to 2 hours, after which measurements shall be made.	容量变化: 在初始值±15%范围内。 损耗角正切值: 不超过规定值。 漏电流: 不超过规定值 外观:无异状 Variation of capacitance: Within ±15% of the value before test. Dissipation factor: Not more than the specified value Leakage Current :Not more than the specified value Appearance: No remarkable abnormality.

7. 内部结构及材料表 Frame and material

7.1 构造图(Frame drawing)及芯包分解图 (Element drawing)

铝电解电容结构图

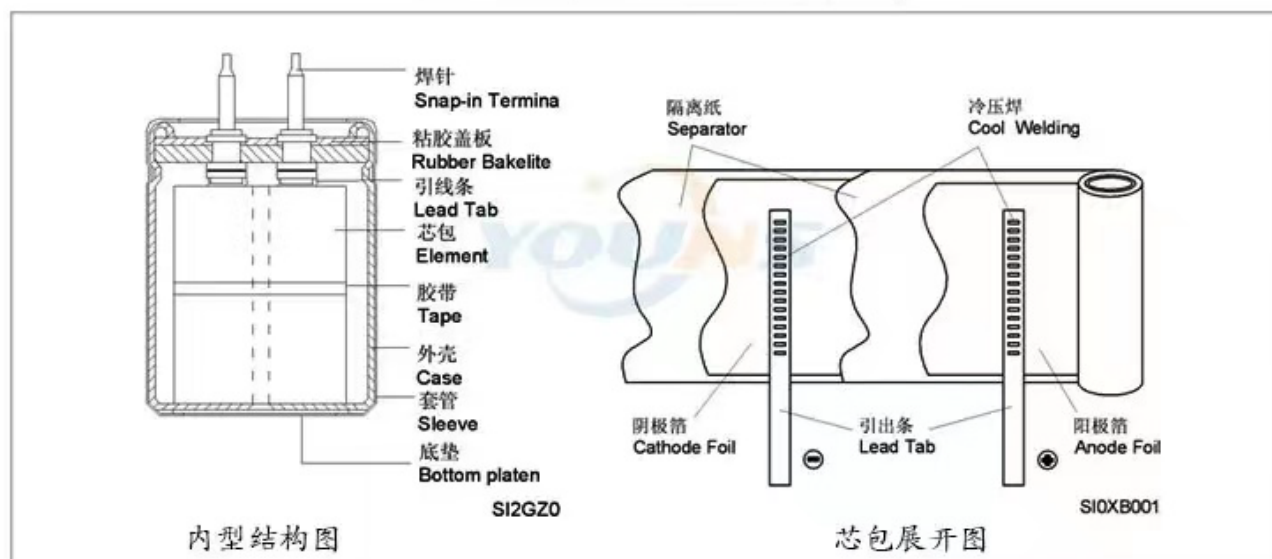

7.2 材料表 Material Table

构成部件	材质	构成部件	材质
正极箔	铝	电解液	有机溶液
负极箔	铝	铝壳	铝
引出条	铝	盖板	铝钉+端子
电解纸	纤维	套管	PVC

	SPECIFICATION	
	SERIES	HP
		Page 11

8 其它说明

8.1 铝电解电容器使用注意事项 Important information on the application of aluminum electrolytic capacitors

(1) .直流铝电解电容器应按正确的极性使用 DC electrolytic capacitors are polarized

当直流铝电解电容器按反极性接入电路时，电容器会导致电子线路短路，由此产生的电流会引致电容器损坏。若电路中有可能在负引线施加正极电压，请选正极性产品。

When reverse voltage is applied on DC electrolytic capacitor, the capacitor will become short circuited please use non polarized capacitors in the circuit are damage due to abnormal current flows through the capacitors since the circuit where the positive voltage may be applied to the cathode terminal.

(2) .在额定工作电压以下使用 Use capacitor within rated voltage

当电容器上所施加电压高于额定工作电压时，电容器的漏电流将上升，其电气特性将在短时期内劣化直至损坏。请注意电压峰值勿超出额定工作电压。

When capacitor is used at higher voltage than the rated voltage, leakage current increases, characteristics drastically deteriorate and damage in a short period may occur as a result .please take extra caution that the peak voltage should not exceed the rated voltage.

(3) .作快速充放电使用 Charge and discharge application

当常规电容器被用作快速充电用途。其使用寿命可能会因为容量下降，温度急剧上升等而缩减。

When aluminum electrolytic capacitors for general purpose are employed in rapid charge and discharge application, its life expectancy may be shortened by capacitance decrease, heat rise, etc.

(4) .电容器贮存 Store the capacitor

当铝电解电容器作了长期贮存后,其漏电流通常升高.贮存温度愈高,漏电流上升愈快.因此应注意贮存环境的选择,在电容器上施加电压后,漏电流值将不断下降,在铝电解电容器的漏电流值上升对电路有不良影响的,请在使用前充电处理.

I creased leakage current is common in aluminum capacitors which have been stored for long period of time .The higher the storage temperature, the higher the leakage current increase therefore please take precautions concerning the storage location. The leakage current causes problems in the circuit, apply voltage (aging) before using.

(5).施加纹波电流应小于额定值 Ripple current applied to capacitor should not exceed the rated value.

施加纹波电流超过额定值后,会导致电容器体过热,容量下降,寿命缩短.所施加纹波电压的峰值应小于额定工作电压.

Excessive heat will reduce capacitance and result in shortened life of capacitor if ripple currents exceeding the specified rated value are applied .the peak value of the ripple voltage should be less than the rated voltage.

	SPECIFICATION		
	SERIES	HP	Page 12

(6)、引出线强度 Lead stress

当拉力施加到电容器引出线，该拉力将作用于电容器内部，这将导致电容器内部短路、开路或漏电流上升。在电容器焊装到电路板，请勿强烈摇动电容器。

When a strong force is applied to the lead wires or terminals. Stress is put on the internal connections. This may result in short circuit, open circuit or increased leakage current .It is not advisable to bend or handle a capacitor after it has been soldered to the PC board.

(7)、焊接过程耐热性 Heat resistance at the soldering process

铝电解电容器装至电路板进行浸焊或波焊时，其塑料套管可能因焊接时间过长、温度过高而发生破裂或二次收缩。

In the dip soldering process of PC board with aluminum electrolytic capacitors mounted, secondary shrinkage or crack of PVC sleeve may be observed when solder temperature is too high or dipping time is too long.

(8)、电路板的安装孔孔距及安装位置 Hole pitch and position of PC board.

电路板的安装孔的设计应与产品说明书的引线脚距相一致，如果将电容器强行插入孔距不配套的电路板，那么会有应力作用于引出线，这将导致短路或漏电流上升。

A PC board must be designed so its hole pitch coincides with the lead pitch(lead spacing) of the capacitor specified by the catalog or specifications .When a capacitor is forcibly inserted into an unmatched hole pitch ,a stress is put on the leads This could result In a short circuit or increased leakage current.

8.2 本产品无铅、无污染 This product is lead free and environmental friendly

本产品（包括所有构件）完全符合欧盟 RoHS 要求，即 6 种有害物质的最大含量均不超过如下要求：

This product is according to the standard of RoHS , it means the max capacitance of six harmful material not over the following request:

Cd (镉) -100PPM

PB (铅) -1000PPM

Hg (汞) -1000PPM

Cr⁴ (6 价铬) -1000PPM

PBBs (多溴联苯) -1000PPM

PBDEs (多溴联苯醚) -1000PPM