

NOTES:

1. Rating:300V 10A;
2. Insulation Withstands Voltage: AC2000V/MIN
3. Insulation Resistance:
500MΩ or more at DC500V
4. Using Temperature Range: -40°C/+105°C
5. Screw Torque Vlaue:0.4N.m
6. Suitable Electric Wire: 28-16AWG
- 7, "★" the important dimension.

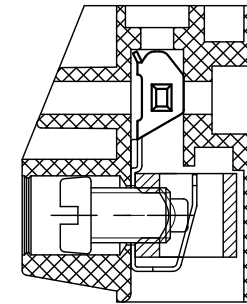

SECTION:A-A

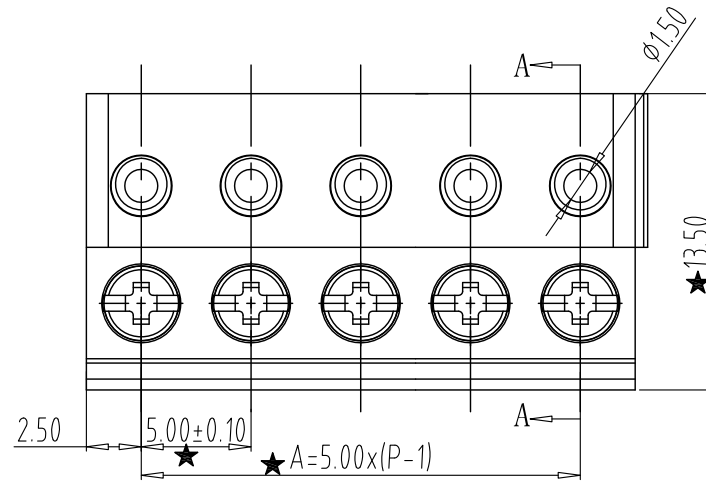
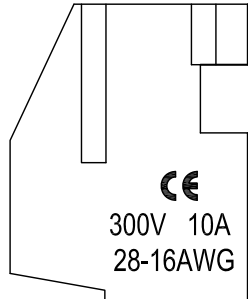
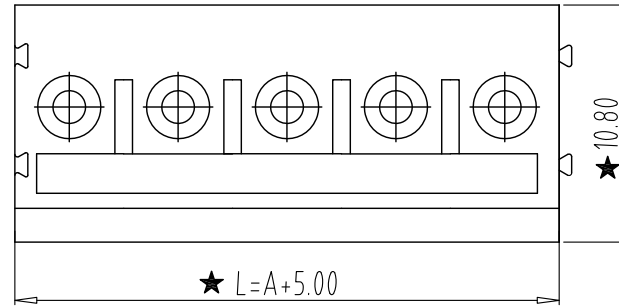
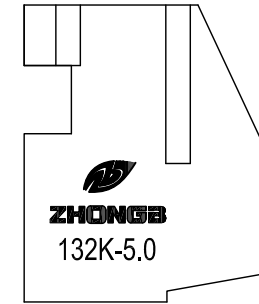

Total Pitch Tolerances in mm										Nominal dimension range in mm										⊥	≡	-	//			
over 0	over 30	over 53	over 70	over 90	over 115	over 150	over 250	over 350	over 500	over 0	over 30	over 53	over 70	over 90	over 115	over 150	over 200	over 250	over 320	over 0	over 10	all	over 0	over 100	over 150	over 150
±0.18	? .20	±0.25	±0.3	±0.35	? .44	±0.60	±0.70	? .85	±0.20	±0.25	±0.30	±0.35	±0.44	±0.55	±0.70	±0.80	±0.90	0.2	0.3	0.3	0.2	0.3	0.5			

ITEM	NAME OF PART	NO. OF PART	Q'TY	MATERIAL	NOTE
DWG.	ZX	DATE	SIZE	A4 UNITS mm	SHEET/OF 1 / 1
CHK.	DATE		SCALE	3:1	
APP.	DATE				
 NINGBO ZHONGBO PHOTOVOLTAIC TECHNOLOGY CO., LTD			NAME	ZB132K-XXP-XC(332K-5.0)	
			DWGNO.	ZB-02-ZB332KXXPC	