

KP

2010

Size: 20\*20\*10 mm

CE RoHS

## DC轴流风扇



轴承结构: 滚珠和含油结构

Bearing system: Ball or Sleeve

外框材质: 环保防火 PBT UL 94V-0

Frame: Thermal Plastic PBT UL 94V-0

扇叶材质: 环保防火 PBT UL 94V-0

Impeller: Thermal Plastic PBT UL 94V-0

风扇单重: 3.8g

Weight: 3.8g



P&Q曲线 (额定电压)

P&Q CURVE(AT RATED VOLTAGE)

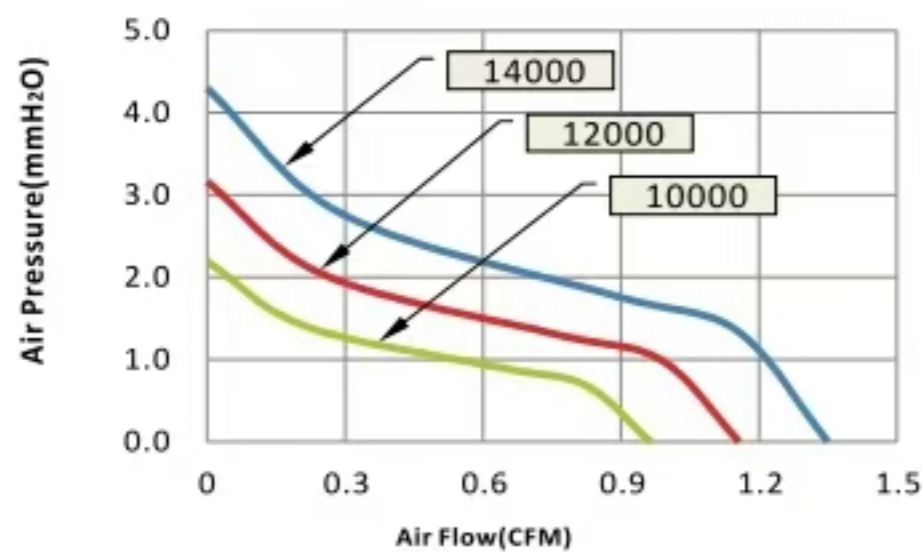

尺寸图

DIMENSIONS DRAWING

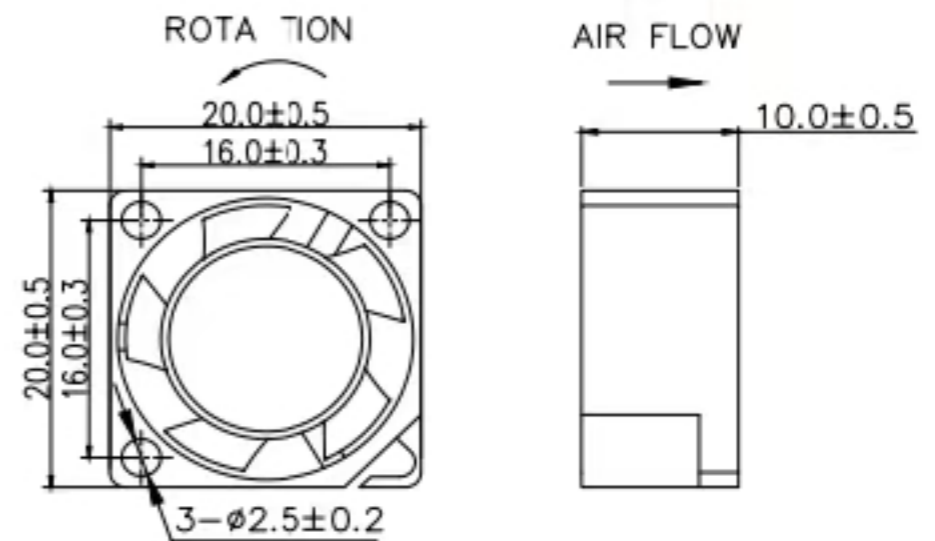

### 风扇可选功能列表

### List of optional fan functions

#### 1、马达保护 Motor protection

RP	SS	LP	CL	OVP
●	○	●	○	○

#### 2、信号输出 Signal output

FG	RD	RDB	LD
●	●	○	○

#### 3、调速方式 Speed control model

PWM	TC	VC	CC	CS
○	○	○	○	○

型号 Model	轴承类型 Bearing system	额定电压 Rated Voltage	工作电压范围 Operation Voltage Range	额定电流 Rated Current	输入功率 Input Power	额定转速 Rated Speed	最大风量 Max Air Flow		最大风压 Max Static Pressure		噪音 Noise
							CFM	m <sup>3</sup> /min	mmH <sub>2</sub> O	Inch-H <sub>2</sub> O	
PART NO.	B/S	VDC	VDC	A	Watt	RPM	CFM	m <sup>3</sup> /min	mmH <sub>2</sub> O	Inch-H <sub>2</sub> O	dBA
KP2010HDB05	Ball	5	4.0~5.5	0.30	1.50	14000	1.35	0.038	4.30	0.169	24.0
KP2010MDB05			4.0~5.5	0.20	1.00	12000	1.57	0.044	3.15	0.124	21.0
KP2010LDB05			4.0~5.5	0.15	0.75	10000	0.96	0.027	2.19	0.086	18.5
KP2010HDS05	Sleeve		4.0~5.5	0.30	1.50	14000	1.35	0.038	4.30	0.169	24.0
KP2010MDS05			4.0~5.5	0.20	1.00	12000	1.57	0.044	3.15	0.124	21.0
KP2010LDS05			4.0~5.5	0.15	0.75	10000	0.96	0.027	2.19	0.086	18.5
KP2010HDB1	Ball	12	6.0~13.2	0.10	1.20	14000	1.35	0.038	4.30	0.169	24.0
KP2010MDB1			6.0~13.2	0.08	0.96	12000	1.57	0.044	3.15	0.124	21.0
KP2010LDB1			6.0~13.2	0.04	0.48	10000	0.96	0.027	2.19	0.086	18.5
KP2010HDS1	Sleeve		6.0~13.2	0.10	1.20	14000	1.35	0.038	4.30	0.169	24.0
KP2010MDS1			6.0~13.2	0.08	0.96	12000	1.57	0.044	3.15	0.124	21.0
KP2010LDS1			6.0~13.2	0.04	0.48	10000	0.96	0.027	2.19	0.086	18.5